

ASDO TIE BAR DESIGN CAPACITIES

ASDO tie bars can be supplied in two grades of carbon steel and stainless steel. All components are designed to exceed the capacity of the bar.

Table 1 - ASDO grade

	ASDO350-S	ASDO540-S					ASDOE600-S		
Nominal thread size	M100 - M130	M12	M16-42	M45-85	M90 - M100	M105 - M160*	M12 - M42	M48 - M56	
f_y [N/mm ²]	355	355	540	540	520	630	600	460	
f_{ub} [N/mm ²]	510	510	700	700	700	710	800	650	

Minimum elongation for all grades 17%; Minimum charpy for all grades 27J @ -20 °C; ASDO350-S M140-M160 differ from above, refer to table 3 for design resistance
*ASDO540-S bars M105-M160 are quench and tempered and should not be galvanised

Table 2 - Standard stock bar lengths

Nominal thread size		ASDO350-S	ASDO540-S	ASDOE600-S
M16-M42	m	-	12	6
M45-M100	m	-	16	6
M105-M160	m	16	12	-

For longer system lengths bars are connected using couplers or turnbuckles. M12 available in 6m lengths only.

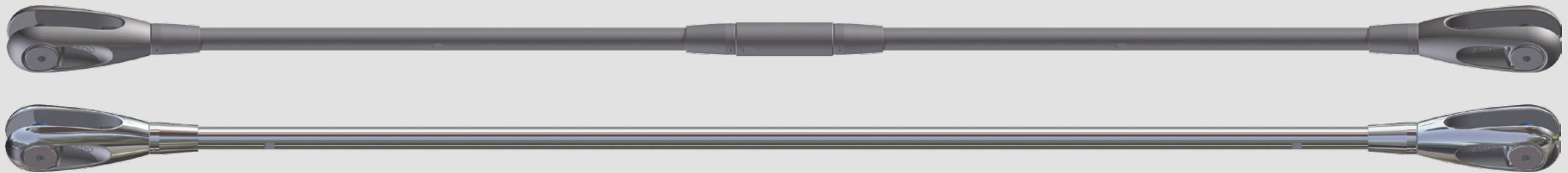

Table 3 - Carbon steel

Dimensional data			M12	M16	M20	M24	M27	M30	M36	M42	M45	M48	M52	M56	M60	M64	M68	M72	M76	M80	M85	M90	M95	M100	M105	M110	M115	M120	M130	M140	M150	M160	
Nominal thread size																																	
Nominal shaft size	mm		12	16	20	24	27	30	36	42	45	48	52	56	60	64	68	72	76	80	85	90	95	100	105	110	115	120	130	140	150	160	
Shaft area, A_s	mm ²		113	201	314	452	573	707	1,018	1,385	1,590	1,810	2,124	2,463	2,827	3,217	3,632	4,072	4,536	5,027	5,675	6,362	7,088	7,854	8,659	9,503	10,387	11,310	13,273	15,394	17,671	20,106	
Thread pitch	mm		1.75	2	2.5	3	3	3.5	4	4.5	4.5	5	5	5.5	5.5	6	6	6	6	6	6	6	6	6	6	6	6	6	6	6	6	6	
Thread stress area, A_s	mm ²		84	157	245	353	459	561	817	1,121	1,306	1,473	1,758	2,030	2,362	2,676	3,055	3,460	3,889	4,344	4,948	5,591	6,273	6,995	7,755	8,556	9,395	10,274	12,149	14,181	16,370	18,716	
Weight per metre (bar)	kg/m		0.9	1.6	2.5	3.6	4.5	5.5	8.0	10.9	12.5	14.2	16.7	19.3	22.2	25.3	28.5	32.0	35.6	39.5	44.5	49.9	55.6	61.7	68.0	74.6	81.5	88.8	104.2	120.8	138.7	157.8	
Load capacities	ASDO350-S	Yield	kN	-	-	-	-	-	-	-	-	-	-	-	-	-	-	-	-	-	-	-	-	2,483	2,753	3,037	3,335	3,647	4,313	4,183	4,829	5,334	
	ASDO540-S	Yield	kN	30	85	132	190	248	303	441	605	705	795	949	1,096	1,275	1,445	1,650	1,868	2,100	2,346	2,672	2,907	3,262	3,637	4,886	5,390	5,919	6,472	7,654	8,934	10,313	11,791
Design resistance ¹	ASDO350-S	$F_{t,Rd}$	kN	-	-	-	-	-	-	-	-	-	-	-	-	-	-	-	-	-	-	-	-	2,535	2,795	3,067	3,352	3,650	4,284	4,128	4,739	5,209	
	ASDO540-S	$F_{t,Rd}$	kN	31	79	123	178	232	283	412	565	658	742	886	1,023	1,190	1,349	1,540	1,744	1,960	2,189	2,494	2,818	3,162	3,525	3,965	4,374	4,803	5,252	6,210	7,249	8,368	9,568

Table 4 - Stainless steel

Dimensional data			M12	M16	M20	M24	M27	M30	M36	M42	M48	M56	M60+	
Nominal thread size														
Nominal shaft size	mm		10.8	15	18	22	25	28	34	39	45	52		
Shaft area, A_s	mm ²		92	177	254	380	491	616	908	1,195	1,590	2,124		
Thread pitch	mm		1.75	2	2.5	3	3	3.5	4	4.5	5	5.5		
Thread stress area, A_s	mm ²		84	157	245	353	459	561	817	1,121	1,473	2,030		
Weight per metre (bar)	kg/m		0.7	1.4	2.0	3.0	3.9	4.9	7.3	9.6	12.7	17.0		
Load capacities	ASDOE600-S	Yield	kN	51	94	147	212	276	336	490	673	678	934	Larger diameters available at request
		Ultimate	kN	67	125	196	282	368	448	653	897	958	1,320	
Design resistance ¹		$F_{t,Rd}$	kN	47	87	136	195	255	311	453	621	656	900	

Notes for tables 3 & 4:
 1. Design tensile resistance $F_{t,Rd} = \min \{ f_t \times A_s / \gamma_{M2}; 0.9 \times f_{ub} \times A_s / \gamma_{M2} \}$ as per EN1993-1-8 with partial factors $\gamma_{M2} = 1.0$ & $\gamma_{M2} = 1.25$ for carbon steel and $\gamma_{M2} = 1.1$ & $\gamma_{M2} = 1.25$ for stainless steel according EN1993-1-4
 2. For the full design resistance to be utilised connection plates must be fabricated from S355J2 to EN10025 (or equivalent) and to minimum dimensions given in table 5
 3. All threads are cut threads and are not suitable for dynamic loads. Rolled threads with higher fatigue resistance can be made on request - please contact our technical department
 4. For full design capacity threads must be engaged at least 1.2 x thread diameter, see installation guide page 17
 5. Stainless steel bar grades M12-M42 are austenitic 1.4401/4, M48+ are duplex 1.4462.

Corrosion protection

ASDO systems can be supplied self colour or galvanised as standard. Sizes up to M42 are supplied with forks, pins, turnbuckles, couplers and thread-cover sleeves hot dip galvanised as standard. Note ASDO540-S bars M105-M160 are quench and tempered steel and therefore should not be galvanised.

Bar threads can be formed after galvanising or are re-machined to size following galvanizing; repairs to the zinc coating are made in accordance with DIN EN ISO 1461. Spanner flats on the tie-rods are pressed following hot galvanizing to prevent brittle fracture. Note, due to the nature of the galvanising process the visual finish of galvanised product is variable. If a high level of aesthetic finish is required systems should be subsequently painted after a suitable primer has been applied. ASDO tie bars cannot be supplied with 'top-coat' finishes, this should be applied by the customer. Please advise us before placing an order if bars are intended to be painted.



Please contact our technical department for more detail.

ASDO DIMENSIONAL DATA

The components shown are generic and the design of pins, couplers and turnbuckles may change dependent on bar diameter. Turnbuckles and couplers from M105 to M160 have a cross bore instead of spanner flats.

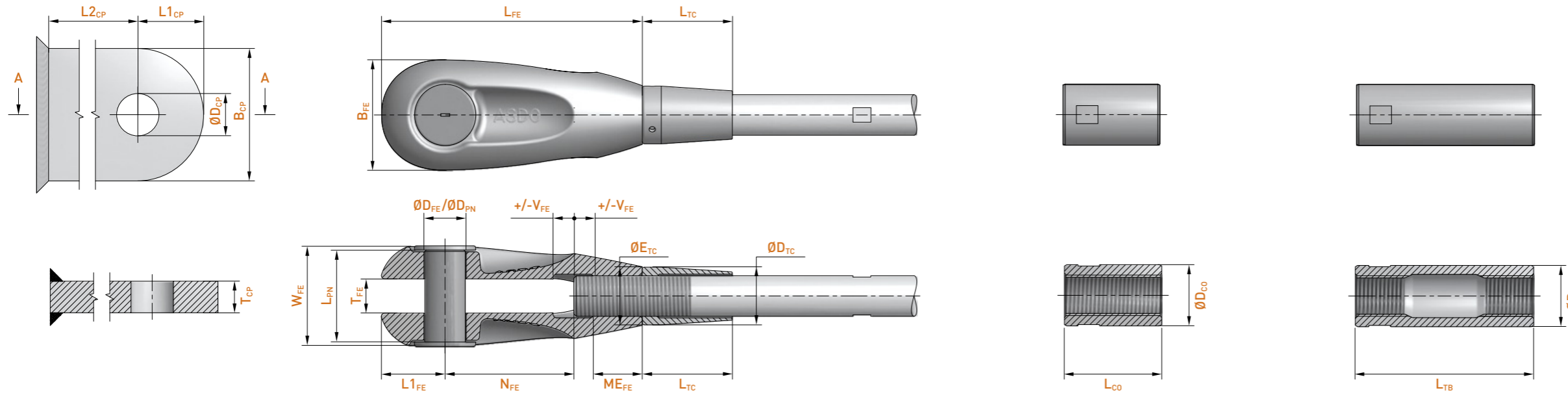

Table 5 - Dimensions for ASDO fittings - all grades (carbon and stainless)

Nominal size	M12	M16	M20	M24	M27	M30	M36	M42	M45	M48	M52	M56	M60	M64	M68	M72	M76	M80	M85	M90	M95	M100	M105	M110	M115	M120	M130	M140	M150	M160	
FE Fork end	L _{FE}	77	104	129	155	172	193	232	271	290	310	334	361	386	412	438	463	489	516	547	579	610	645	677	709	742	773	837	901	966	1,031
	B _{FE}	33	44	53	65	73	81	98	114	122	130	139	150	159	172	182	193	203	219	230	243	258	271	287	301	316	330	354	381	410	436
	W _{FE}	31	42	50	61	66	77	90	104	108	119	126	139	149	159	167	179	191	196	211	226	237	248	259	271	284	303	327	351	375	405
	T _{FE}	12	17	18	23	23	28	33	38	38	44	44	49	54	59	59	64	69	74	79	84	89	94	96	101	106	116	126	136	146	156
	ØD _{FE}	13	17	21	25	28	32	38	44	47	50	54	58	62	66	70	74	78	82	87	92	97	102	108	113	118	123	133	143	153	163
	L _{1FE}	19	26	31	38	42	47	57	66	71	76	81	88	93	100	106	112	119	128	133	140	150	160	167	175	184	191	207	222	239	255
	ME _{FE}	14	19	24	29	32	36	43	50	54	58	62	67	72	77	82	86	91	96	102	108	114	120	126	132	138	144	156	168	180	192
	N _{FE}	38	51	64	76	84	95	114	134	143	152	166	181	196	210	225	240	254	267	287	306	321	340	359	377	395	413	449	486	522	559
	+/-V _{FE}	6	8	10	12	13,5	15	18	21	23	24	25	25	25	25	25	25	25	25	25	25	25	25	25	25	25	25	25	25	25	25
	Weight [kg]	0.17	0.42	0.83	1.4	2.0	2.8	4.8	7.6	9.4	11	15	18	22	27	33	39	45	51	63	74	85	100	119	136	156	177	221	277	340	417
PN Pin	ØD _{PN}	12	16	20	24	27	30	36	42	45	48	52	56	60	64	68	72	76	80	85	90	95	100	105	110	115	120	130	140	150	160
	L _{PN}	30	40	47	57	63	73	85	97	102	111	120	129	140	151	157	166	175	182	195	205	218	229	241	250	261	277	301	323	344	365
	Weight [kg]	0.03	0.07	0.14	0.25	0.34	0.46	0.81	1.2	1.5	2	2	3	4	5	5	6	7	8	11	12	14	16	19	22	25	29	37	46	57	71
CP Connection plate	T _{CP}	10	15	15	20	20	25	30	35	35	40	45	50	55	55	60	65	70	75	80	85	90	90	95	100	110	120	130	140	150	
	B _{CP}	42	56	68	80	90	104	122	142	152	160	174	186	200	212	224	238	250	264	280	296	312	328	346	362	378	394	426	458	490	522
	ØD _{CP}	13	17	21	25	28	32	38	44	47	50	54	58	62	66	70	74	78	82	87	92	97	102	108	113	118	123	133	143	153	163
	L _{1CP}	21	28	34	40	45	52	61	71	76	80	87	93	100	106	112	119	125	132	140	148	156	164	173	181	189	197	213	229	245	261
	L _{2CP} (min)	29	36	46	53	57	62	72	81	86	91	101	108	113	120	126	132	139	148	153	160	170	180	192	200	209	216	232	247	264	280
TC Locking thread cover	ØE _{TC}	17	23	29	35	39	42	51	60	64	69	75	81	87	92	99	104	110	113	122	129	134	143	152	158	166	173	187	202	216	232
	L _{TC}	30	40	50	55	60	70	80	95	100	110	115	120	120	135	135	135	135	140	140	140	140	140	140	140	140	140	140	140	140	140
	Weight [kg]	0.03	0.05	0.09	0.1	0.2	0.3	0.4	0.7	0.8	1.1	1.3	1.6	1.8	2.2	2.7	2.9	3.3	3.6	4.2	4.7	4.9	5.7	6.6	7.0	7.8	8.6	10	12	13	15
TB Turnbuckle	ØD _{TB}	20	27	36	42	48	51	60	70	76	83	89	95	102	108	114	121	127	133	140	152	159	171	178	191	194	203	219	241	254	273
	L _{TB}	53	70	88	106	119	132	158	185	198	211	225	234	244	254	263	273	282	292	304	326	338	350	387	399	411	423	447	471	495	519
	+/-V _{TB}	12	16	20	24	27	30	36	42	45	48	50	50	50	50	50	50	50	50	50	50	50	50	50	50	50	50	50	50	50	50
	Weight [kg]	0.09	0.16	0.32	0.6	0.9	1.2	1.8	2.8	3.3	3.9	5.4	6.2	8.5	10	12	14	16	18	20	24	30	34	42	49	62	61	82	96	115	147
CO Coupler	ØD _{CO}	20	27	36	42	48	51	60	70	76	83	89	95	102	108	114	121	127	133	140	152	159	171	178	191	194	203	219	241	254	273
	L _{CO}	29	39	48	58	65	72	87	101	108	116	125	135	144	154	164	173	183	192	204	226	238	250	287	299	311	323	347	371	395	419
	Weight [kg]	0.05	0.09	0.17	0.3	0.5	0.7	1.1	1.7	2.0	2.3	3.2	3.9	5.3	6.3	7.8	9.2	11	12	14	17	22	25	32	37	47	47	65	77	93	119

All dimensions in mm unless noted otherwise

